

# Surge-Trap<sup>®</sup> Type 1 XP Series SPD

The Surge-Trap<sup>®</sup> Type 1 XP Series offers advanced performance over other products. The XP meets requirements for UL 1449 Third Edition and has been designed to be as compact as possible while offering advanced protection. The XP features TPMOV<sup>®</sup> technology inside making it the safest product available. Installation can be done on the line or load side of a panel. The XP is the perfect fit from service entrance all the way down to an important machine specific control panel.

## Features/Highlights:

- UL 1449 Third Edition Listed, Type 1 SPD (Sept. 2009)
- Can be installed line-side or load-side of main disconnect
- 20kA Nominal discharge current
- 200kA SCCRs (most models)
- UL 96A Lightning Protection Master Label compliant (@20kA In)
- Pre-wired with 3' (1m) of #10 AWG conductor
- Voltage specific design – highly configurable
- All MOV suppression elements monitored
- NEMA 4X enclosure
- Ten-year warranty
- Phase-loss monitoring (toggles LED and dry contacts)

## Applications:

- AC Distribution
- Power supplies
- Drive Protection
- Fire Alarms
- Control Panels
- Telecommunications
- Residential
- IT / Data centers



## Ratings:

**Surge** : 100kA  
 Phase L-N L-G N-G  
 50kA 50kA 50kA

**Volts** : 120 - 600

**SCCR** : 200kA (most models)

**Nominal discharge current**  
 : 20kA (most models)

**Operating & storage temp**  
 : -25°C to +60°C

**Enclosure**  
 : NEMA 4x

## Dimensions and Weight

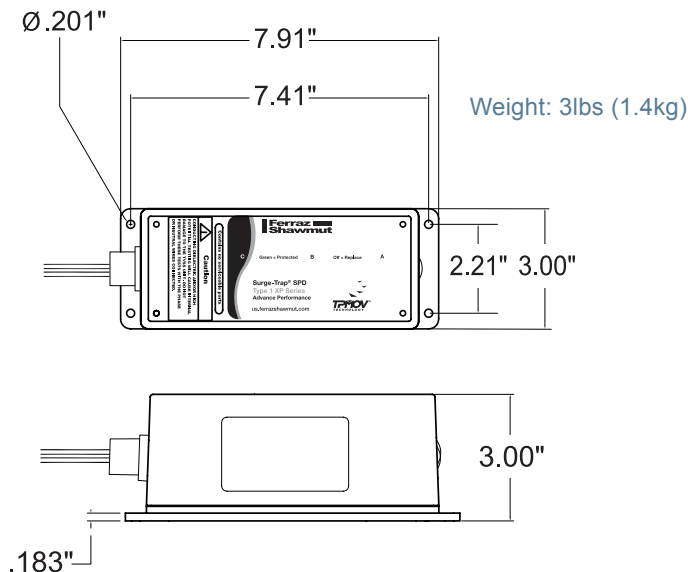

## Approvals:

- UL 1449 Third Edition, (cUL Type 2 optional)
- UL File VZCA.E210793
- RoHS Compliant
- IEC 61643, CE
- Burn-In tested prior to shipment
- UL 96A lightning protection master label



# Surge-Trap<sup>®</sup> Type 1 XP Series SPD

## Catalog - Ordering System

STXP	System Voltage	S	Surge Rating	Enclosure	Options
	<b>Common System Configurations</b> 01 = 240/120V Split Phase - 1Φ 3W+Grnd (Fig 1) 02 = 208Y/120V Wye - 3Φ 4W+Grnd (Fig 2) 03 = 240/120V High Leg Delta (B High) (Fig 3) 04 = 480Y/277V Wye - 3Φ 4W+Grnd (Fig 2) 05 = 480V Delta - 3Φ 3W+Grnd (Fig 4) & HRG Wye 08 = 600Y/347V Wye -3Φ 4W+Grnd (Fig 2)				Blank A = Audible Alarms & Dry Contacts E = Remote Indicator (on 6ft cable) L = Deletes L-N protection G = Deletes L-G protection N = Deletes N-G protection R = Alternate lead length
	<b>Other System Configurations Available</b> 06 = 240V Delta - 3Φ 3W+Grnd (Fig 4) 07 = 380Y/220V Wye - 3Φ 4W+Grnd (Fig 2) 09 = 600V Delta - 3Φ 3W+Grnd (Fig 4) & HRG Wye 11 = 120V Single Phase (Fig 5) 12 = 240V Single Phase (Fig 5) - Not split phase 13 = 127V Single Phase (Fig 5) 14 = 300V Single Phase (Fig 5) 15 = 254/127V Split Phase - 1Φ 3W+Grnd (Fig 1) 16 = 277V Single Phase (Fig 5) 17 = 480V Single Phase (1 Hot, 1 Neu, 1 Grnd) (Fig 5) 18 = 480/277 2-Pole, (480/240V Split Phase) (Fig 1) 21 = 220Y/127V Wye - 3Φ 4W Grnd (Fig 2) 41 = 520Y/300V Wye- 3Φ 4W+Grnd (Fig 2) 42 = 415Y/240V Wye-3Φ 4W+Grnd (Fig 2) 43 = 400Y/230V Wye - 3Φ 4W+Grnd (Fig 2) 44 = 440Y/250V Wye - 3Φ 4W+Grnd (Fig 2) 51 = 480V B Corner Grnd Delta, 3Φ 3W+Grnd (Fig 6) 61 = 240V B Corner Grnd Delta, 3Φ 3W+Grnd (Fig 6) 91 = 600V B Corner Grnd Delta, 3Φ 3W+Grnd (Fig 6)				
STXP		S	100	4X	
<b>Example</b>	<b>STXP05S1004XE</b>				
STXP	05	S	100	4X	E

## Wiring Diagrams

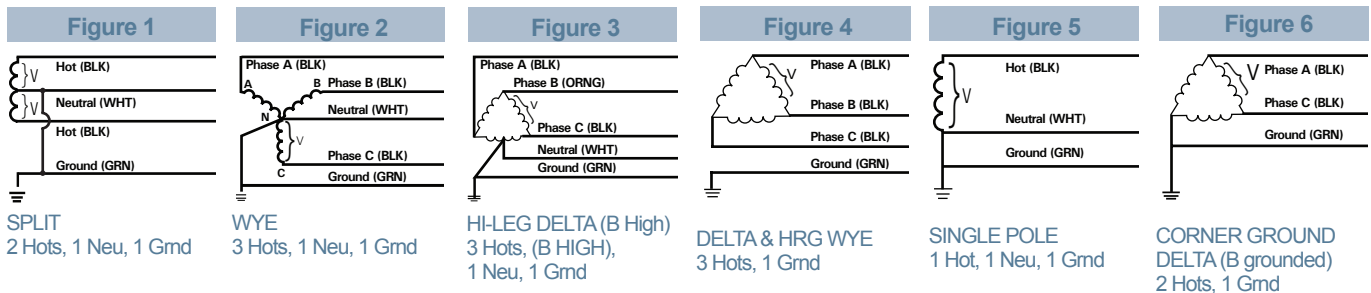

## Performance Data

Common North American Systems		UL 1449 THIRD Edition (Sept 2009) Test Data Voltage Protection Ratings (VPR - 3kA)							
		L-N	L-G	N-G	L-L	Type	In	SCCR	MCOV
01	= 240/120V Split Phase	600	700	500	1000	Type 1	20kA	100kA	150
02	= 208Y/120V 3Ø Wye	600	700	500	1000	Type 1	20kA	200kA	150
03	= 240Y/120V B High Leg Delta	600/1200	700/1200	500	1000	Type 1	20kA	200kA	150 / 320
04	= 480Y/277V 3Ø Wye	1200	1200	1000	1800	Type 1	20kA	200kA	320
05	= 480V 3Ø Delta	-	1800	-	1800	Type 1	10kA	200kA	552
08	= 600Y/347V 3Ø Wye	1500	1500	1500	2500	Type 1	10kA	200kA	420

## Available Accessories\*

FMKITC = Flush mount kit.

RM = Remote monitor

\*Consult factory for details.

For the most current product performance data visit [us-ferrazshawmut.mersen.com](http://us-ferrazshawmut.mersen.com) and use catalog search.