

SURGE PROTECTION SOLUTIONS

SOLUTIONS GUIDE

Comprehensive overvoltage protection



FERRAZ SHAWMUT IS NOW MERSEN

MERSEN

Surge. Transient Spike. Over Voltage.

**POWER RELATED FLUCTUATIONS COST U.S. COMPANIES
MORE THAN \$80 BILLION A YEAR**

You have expensive equipment you rely on every day to meet your customers needs. Down machines cost you time, money, and resources to get back on line. With a minimal investment, you can protect your sensitive control equipment or your entire facility from surge events. Mersen's Surge-Trap® product line offers a world class suite of surge protection products designed to protect your facility from harmful and preventable surge damage.

Most surge spikes originate from within a customer's own facility. In fact, nearly 80% of all surge problems are directly attributed to power disturbances from within the facilities own equipment.

Any facility with motors stopping and starting, light load panels being turned on and off frequently and other potential power disturbances is at risk for damage caused by a surge spike.

Of course, surges in electrical power can also originate outside of a facility, accounting for roughly 20% of facility transient problems. These surges may be caused by utility grid switching, lightning strikes, switching of capacitor banks and electrical accidents.

What does a voltage surge look like?

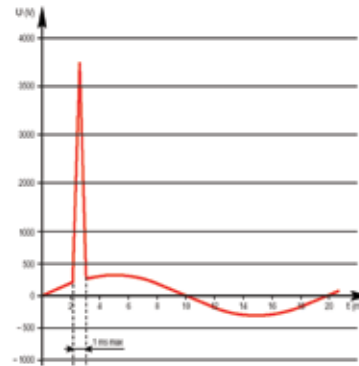

A voltage surge is voltage level that is short in duration and can be several times greater than the systems normal operating AC RMS or DC voltage level.

Although many transients are not predictable, damage to a facility is preventable with a proven and tested surge protection device.

What types of damage can a surge cause to a facility?

- **Disruptive damage:** A surge enters an electronic component which interprets the valid logic command. *The result:* system lock-up, machine malfunction leading to faulty output, or corrupted files.
- **Dissipative:** A repetitive, pulsing of short duration energy. *The result:* Long term machine or system degradation leading to system replacement at earlier intervals.
- **Destructive:** A high level energy surge that immediately results in equipment failure or destruction.

Although many surges are not predictable, damage to a facility is preventable with a proven and tested surge protection device.



Why Mersen?

For Surge Protection That Covers Every Voltage Need Within Your Facility



Mersen offers a comprehensive suite of Surge Protection products, covering every voltage need within a facility.

An industry innovator, Mersen developed the first surge protection device to pass UL 1449 3rd edition safety requirements. All Mersen SPDs feature our Thermally Protected MOV (TPMOV[®]) technology, a fail safe surge protection solution without the need for additional upstream protection. As a result, the Surge-Trap[®] product line offers the lowest installed cost surge protection products on the market.

	Mersen Surge-Trap	Typical Competitor
Surge Protection Device	\$	\$
Fuse	-	\$
Fuse Holder	-	\$
Additional Wiring	-	\$
Installation Cost	\$	\$\$
Panel Footprint	-	\$
Total Product Cost	\$\$	\$\$\$\$\$\$

Mersen offers surge protection products ranging from point of use protection to complete facility protection. The Surge-Trap product line represents the broadest suite of products for all your application requirements.

- **Thermal MOV protection (TPMOV).** Thermal protection eliminates an MOV's hazardous and destructive failure modes
- **Overvoltage is solely managed by TPMOV technology.** This technology eliminates the need for additional wiring, fuse components, and costly installation time
- **Non-Fused MOV protection.** TPMOV is the only non-fused MOV on the market
- **Industry Innovation.** Mersen developed the first SPD product to pass UL1449 3rd edition safety testing, utilizing our patented TPMOV technology
- **Highest Short Circuit Current Rating (SCCR).** Surge-Trap products feature the highest SCCR rating available for any surge protection device, allowing for higher safety ratings and protection
- **Isolated MOV.** Surge-Trap products provide fail safe protection by isolating the MOV at the end of life



Surge Protection: Used Everywhere

UL1449 3rd edition requires that SPD's be designed for repeated limiting of transient voltage surges as specified in the standard on 50 or 60 Hz power circuits not exceeding 1000V. The specifics of SPD products are broken down and designated as follows:

Category 1:

- Permanently connected SPD
- Installed between the secondary service transformer and the line side of the service equipment overcurrent device as well as the load side, including watt-hour meter socket enclosures
- Intended to be installed without an external overcurrent protective device

Category 2:

- Permanently connected SPD
- Installed on the load side of the service equipment overcurrent device
- Includes SPD's located at the branch panel

Category 3:

- Point of utilization SPD's
- Installed at minimum conductor length of 10 meters (30 feet) from the electrical service panel to the point of utilization
 - IE: Cord connected, direct plug-in, receptacle type
- SPD's installed at the utilization equipment being protected
- The distance of 10 meters is exclusive of conductors provided with or used to attach SPD's

Category 4:

- Surge suppression components
 - Can be a basic component or a complete module
- Can be tested to Type 1 or Type 2

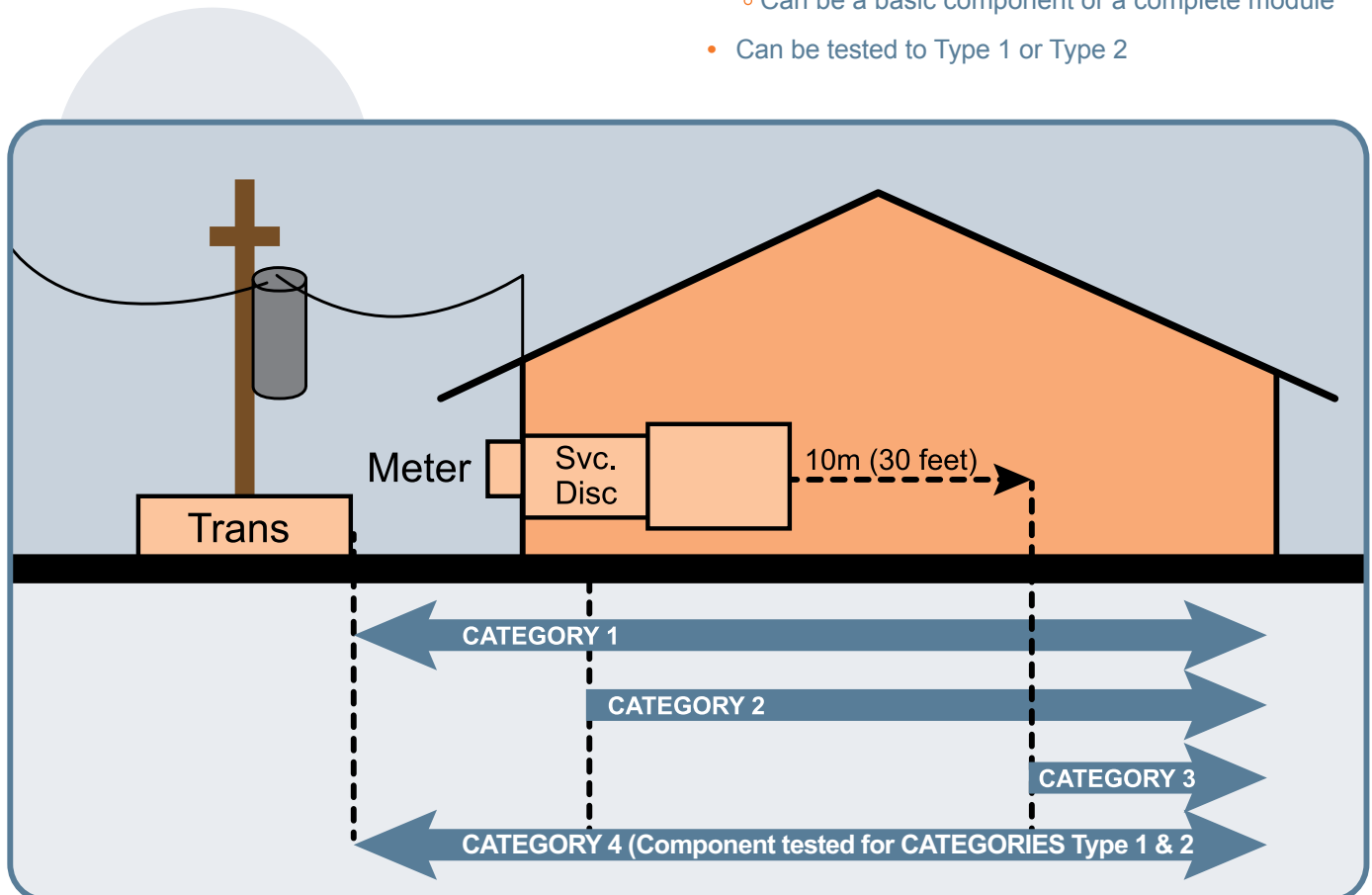

UL[®] Safety Requirements for Surge Protection

MAKE SURE YOUR INSTALLATION COMPLIES WITH UL 1449 3rd EDITION STANDARDS

UL can mark SPDs with two different classifications. A product that fully complies with the UL 1449 3rd Edition revision categories 1, 2, or 3 is marked with a small holographic label bearing the letters SPD. It also has the UL Listing Symbol.

When a product is compliant with category 4 of UL 1449 3rd Revision, UL labels it a Recognized Product.

- Recognized products require additional safety evaluation for the application of the product and normally this type is installed at an OEM or an electrical panel manufacturer location.
- If it is integrated into a listed panel, a UL representative will review the application to confirm it meets safety requirements.
- The UL recognition symbol is shown as a mirror image UR.

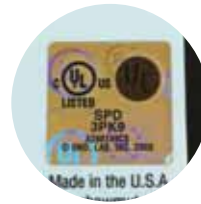

A UL recognized product receives a detailed list of how it is different than a listed product. The UL test report provides the “Conditions of Acceptability”. An OEM and UL field engineer requires this information to assure the SPD is applied safely.

Non-UL listed products can be misleading. Some SPD manufacturers self-test their units using their own opinion of what is important. They can state on the packaging that the SPD is UL 1449 3rd Edition compliant, **but it’s just their opinion.** The use of these products is not in compliance with NEC regulations because they are not listed. Some independent third party testing labs will test to only portions of UL 1449 3rd Edition at the manufacturer’s request.

An example of a product complying with UL 1449 3rd edition and the NEC:

If a maintenance person wanted to protect an existing machine panel against voltage surges, they might select a Mersen STT24803PYG. This is rated 277/480 volts supplied by a three-phase wye solidly grounded neutral source with not over 200kA short-circuit current. This is UL listed for a fully compliant field installation.

An OEM could select either the Mersen STT24803PYG as above, or the Mersen STP4803PYM, which is UL recognized. If the UL recognized product is chosen, the application must meet the UL “Conditions of Acceptability”. In this example, mounting the SPD inside of the machine panel fully complies.

If there is any question about the veracity of an UL SPD status, UL has an easy verification procedure on their website at www.ul.com. At the bottom of the home page, click on Certifications. Then enter the name of the manufacturer to verify the appropriate UL listing.

Meeting the Worlds Toughest Standards

SURGE PROTECTION TERMS TO KNOW



There are many unique surge protection terms that are helpful to know, below is a glossary of frequently used terms:

Glossary of Overvoltage Protection Terms

8/20 current impulse current: Impulse with a virtual front time¹ of 8 μ s and a time to half-value² of 20 μ s.

Clamp Voltage: The peak MOV terminal voltage measured with an applied 8/20 μ s pulse of rated impulse current.

Metal Oxide Varistor (MOV): An electronic component that is commonly used to divert excessive current to the ground and/or neutral lines.

Maximum Continuous Operating Voltage (MCOV): The maximum rms voltage that may be continuously applied to the SPD for each connected mode.

Nominal Discharge Current (I_n): Peak value of the current through the SPD, selected by the manufacturer from a list of predetermined values, having a short-circuit current wave shape of 8/20 μ s where the SPD remains functional after 15 surges.

Voltage Protection Rating (VPR): A rating per UL 1449 3rd Edition, signifying the rounded up average measured limiting voltage of an SPD when the SPD is subjected to the surge produced by a 6 kV, 3kA 8/20 μ s combination waveform generator.

Short Circuit Current Rating (SCCR): The suitability of an SPD for use on an AC power circuit that is capable of delivering not more than a declared rms symmetrical current at a declared voltage during a short circuit condition.

Surge Protective Device (SPD): A device that contains at least one nonlinear component and is listed to limit surge voltages and divert surge current.

Note 1 The front time is defined according to IEC 60060-1 to be 1.25 x (t90 – t10).

Note 2 The time to half-value is defined as the time between the virtual origin and the 50% point on the tail.

NEW TO SURGE PROTECTION?

Mersen offers educational and collaborative product training annually with opportunity for hands on experience to learn more about our products. For information on when the next training will be offered, please contact Mersen USA at 978.462.6662.

Surge-Trap® SPD Products:

A SOLUTION FOR EVERY AREA IN YOUR FACILITY

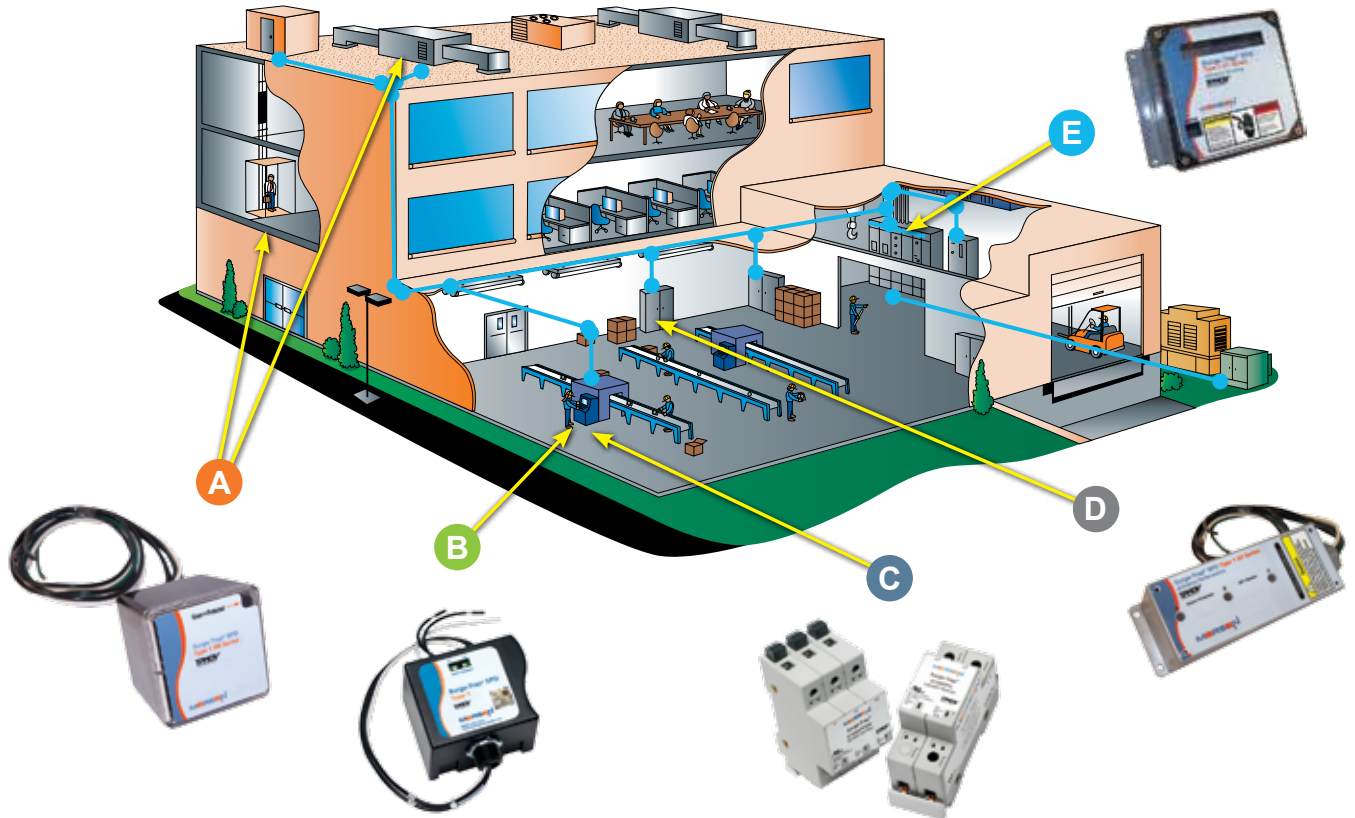

A STXR Series, Listed Type 1 SPD

- End use equipment HVAC – 4X enclosure

B STT2 Series, Listed Type 1 SPD

- End use equipment
- Inside use

C ST Series, UL Recognized Type 4 SPD

- Control panels
- OEM based equipment

D STXP Series, Listed Type 1 SPD

- Distribution panels
- Motor control, automation control
- Larger equipment, drives

E STXT Series, Listed Type 1 SPD

- Service entrance gear
- Main distribution panel board

THE RIGHT SOLUTION FOR YOUR APPLICATION

Surge-Trap Products can be used in a wide variety of applications, including:

- AC/DC distribution
- Power supplies
- Industrial automation
- Telecommunications
- Motor controls and starter systems
- Programmable logic controller (PLC)
- Power transfer equipment
- HVAC applications
- AC drives
- UPS systems
- Security systems
- IT / Data centers
- Medical equipment

Surge-Trap® Type 4 SPDs

DIN-RAIL MOUNTABLE SPD



Featuring Mersen's industry leading patented **TPMOV®** technology, the Surge-Trap Pluggable & Modular SPD's provide advanced surge protection to meet today's toughest requirements. Designed to UL1449 3rd Edition standards, the Surge-Trap product is a fuse free solution eliminating additional wiring, fuse components, and avoids costly installation time, providing customers with a superior, cost effective solution. **Offering the highest short circuit current rating and Mersen's patented thermally protected MOV, there is no need for additional overcurrent protection devices.** Both products offer value-added features including a visual indicator, remote monitoring, and mechanical coding, providing ease of field maintenance.

Surge-Trap Pluggable

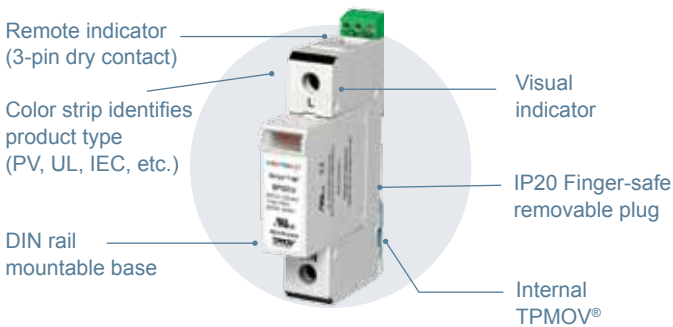

The two-piece technology of the Surge-Trap Pluggable SPD is the newest generation of DIN-rail mountable product, **designed exclusively for both ease of installation and maintenance.** While the base is designed to be mounted on 35mm DIN-rail, **the plugs are designed to be easily replaced upon failure** without touching the base or the hassle of re-wiring a completely new device.

Surge-Trap Modular

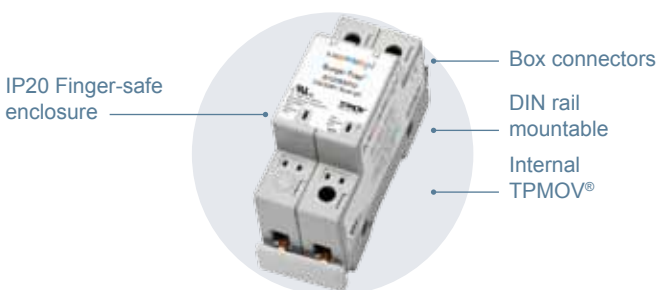

The single piece design of the Surge-Trap Modular SPD is the original and founding product of DIN-rail mountable product in the Surge-Trap Product line. Providing a single piece 25mm DIN-rail solution for surge protection, the units can be completely disposed of and replaced upon failure.

Approvals

- UL 1449 3rd Edition Approved, File E210793
- Type 4 UL Recognized Component
- RoHS Compliant
- ANSI/IEEE C62.41
- CE

Applications

- AC/DC distribution
- Power supplies
- Industrial automation
- Telecommunications
- Motor controls and starter systems
- Programmable logic controller (PLC) applications
- Power transfer equipment
- HVAC applications
- AC drives
- UPS systems
- Security systems
- IT/Data centers
- Medical equipment

Ratings

Volts

- 120V to 600VAC
- 600V to 1000VDC (PV only)

SCCR

- 200kA

Operating & storage temp

- -25°C to +60°C

Wiring range:

- #6 to #14AWG

Nominal discharge current

- 20kA



Surge-Trap[®] Pluggable SPDs

DIN-RAIL STYLE SPD

Surge-Trap Pluggable Surge Protective Device (SPD) is a no-fuse, fail-safe surge suppressor featuring Mersen's patented TPMOV[®] technology inside. The pluggable SPD is UL 1449 3rd Edition approved. It is DIN-rail mountable featuring a fail-safe self-protected design, visual indicator and a small footprint. A remote indicator option provides status to critical control circuits. The Surge-Trap Pluggable SPD has a high short circuit rating and a thermally protected MOV, which eliminates the need for additional overcurrent protection devices.



Dimensions

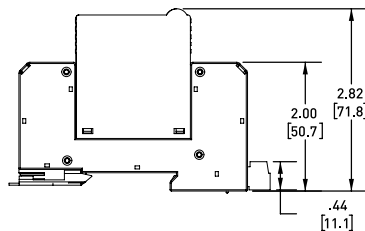
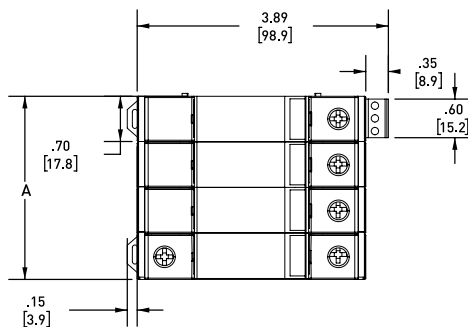
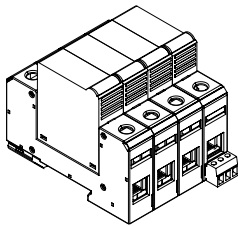

Poles	in	A	mm
1 Pole	0.71	A	18.03
2 Pole	1.42	A	36.06
3 Pole	2.13	A	54.10
4 Pole	2.84	A	72.13

Features/Benefits

- Easy installation or retrofit
- DIN-rail mountable
- Fail-safe, self-protected design
- Remote indicator
- Visual indicator
- IP20 finger-safe design
- Small footprint
- No additional overcurrent protection devices required
- Easy to replace modules
- Two-year warranty

Approvals

- UL 1449 3rd Edition Approved, File E210793
- Type 4 UL Recognized Component
- RoHS Compliant
- ANSI/IEEE C62.41
- CE

Applications

- AC/DC distribution
- Power supplies
- Industrial automation
- Telecommunications
- Motor controls and starter systems
- Programmable logic controller (PLC)
- Power transfer equipment
- HVAC applications
- AC drives
- UPS systems
- Security systems
- IT/Data centers
- Medical equipment

Ratings

- Volts**
- 120V to 600V AC
- SCCR**
- 200kA
- Operating & storage temp**
- -25°C to +60°C
- Wiring range:**
- #6 to #14AWG
- Nominal discharge current**
- 20kA



Surge-Trap® Pluggable SPDs

DIN-Rail Style SPD



Product Type	Voltage	System Type	Mode	Auxiliary Microswitch
STP	480	3PY	G	M
STP - Pluggable	120 120/208 120/240 240 277 347 480 240/480 277/480 347/600	1P - Single Phase SP - Split Phase 3PD - 3 Phase Delta 3PH - 3 Phase Highleg 3PY - 3 Phase Wye	Blank - Includes N-G Mode G - Does Not Provide N-G Mode	M - Microswitch Included

Catalog Numbers

Catalog No.	Nominal Voltage (VAC)	MCOV L-G	No. of Poles	System Type	Nominal Discharge Current ** (In, kA)	Max. Discharge Current (Imax, 8/20µs, kA)	SCCR (kA)	Freq (Hz)	Replacement Plug Part No	Voltage Protection Rating (VPR)				No. of Wires	Circuit Connection Wiring Diagrams
										L-N	L-G	N-G	L-L		
STP1201PGM	120	180	1	1P	20	50	200	50/60	SP180U	600				2	A
STP2083PYM	120/208	360	4	3PY	20	50	200	50/60	SP180U	600	1200	600	1200	5	D
STP2083PYGM	120/208	180	3	3PY	20	50	200	50/60	SP180U	600			1200	4	C
STP2301PGM	240	275	1	1P	20	50	200	50/60	SP275U	900				2	A
STP2403PDGM	240D	275	3	3PD	20	50	200	50/60	SP275U		900		1800	4	C
STP2403PHM	120/240	*	4	3PH	20	50	200	50/60	SP180U, SP275U	600	1200	600	1200	5	E
STP240SPGM	120/240	180	2	SP	20	50	200	50/60	SP180U	600			1200	3	B
STP2771PGM	277	320	1	1P	20	50	200	50/60	SP320U	1000				2	A
STP3471PGM	347	420	1	1P	20	50	200	50/60	SP420U	1500				2	A
STP4803PDGM	480D	550	3	3PD	20	50	200	50/60	SP550U		1800		3000	4	C
STP4803PHM	240/480	*	4	3PH	20	50	200	50/60	SP275U, SP550U, SP180U	900	1500	600	1800	5	E
STP4803PYM	277/480	500	4	3PY	20	50	200	50/60	SP320U, SP180U	1000	1500	600	1800	5	D
STP4803PYGM	277/480	320	3	3PY	20	50	200	50/60	SP320U	1000			1800	4	C
STP480SPGM	240/480	275	2	SP	20	50	200	50/60	SP275U	900			1800	3	B
STP6003PYM	347/600	695	4	3PY	20	50	200	50/60	SP420U, SP275U	1500	2000	900	2500	5	D
STP6003PYGM	347/600	420	3	3PY	20	50	200	50/60	SP420U	1500			2500	4	C

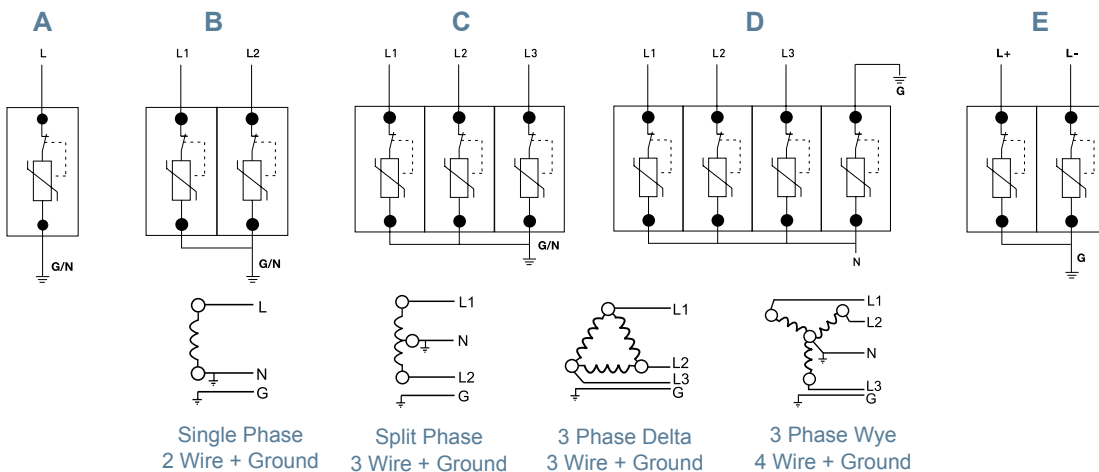

Shine Safe with Mersen

SPECIALIZED PHOTOVOLTAIC (PV) PRODUCT LINE



Specifically designed with the photovoltaic (PV) industry in mind, Mersen's Surge-Trap® PV products leverage the same great TPMOV® technology our customers have grown to rely on.

This world class technology enhances equipment and installation, and with its customer proven simple design, installation, cost, and maintenance is reduced.

Dimensions

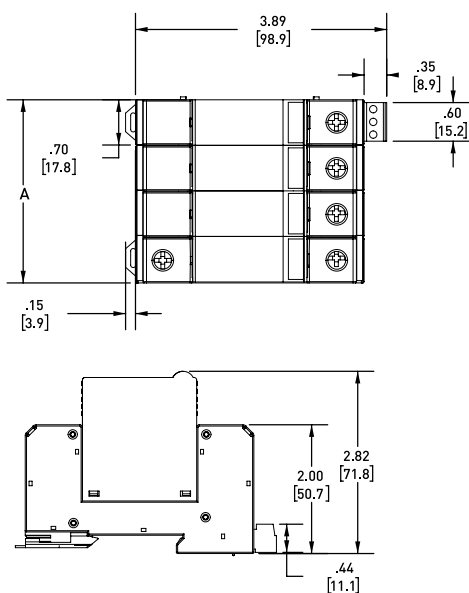
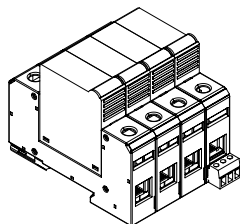

Poles	in	A	mm
1 Pole	0.71	A	18.03
2 Pole	1.42	A	36.06
3 Pole	2.13	A	54.10
4 Pole	2.84	A	72.13



Offering a product line extension in higher voltages, the Surge-Trap PV products offer a fully fail safe protection that is easy to install and retrofit without any additional overcurrent protection needed.

Approvals

- Type 4 UL Recognized Component
- RoHS Compliant
- ANSI/IEEE C62.41
- CE

Ratings

- Volts**
 - 600V to 1000VDC
- SCCR**
 - 10kA
- Operating & storage temp**
 - -25°C to +60°C

Wiring range:

- #6 to #14AWG
- Nominal discharge current**
 - 20kA



Surge-Trap[®] Photovoltaic SPDs

YOUR SOLAR POWER SURGE SOLUTION



Product Type	Voltage	System Type	Mode	Auxiliary Microswitch
STP	480	3PY	G	M
	600	PV - Photovoltaic		
	1000			
	1200			

Catalog Numbers

Catalog No. PV	Nominal Operating DC Voltage (V)	Ucpv*	Nominal Discharge Current (In, 8/20, kA)	I _{max} Discharge Current (I _{max} , 8/20μs, kA)	Voltage Protection Level (Up @ In, kV)	Iscwpv** (kA)	L/R	Replacement Plug Part No	No. of Poles	Wiring Diagrams
STP600PVM	600	720	20	40	<2.5	10	<= 1mS	SP670PV	2	F
STP600YPVM	600	720	20	40	<3.0	10	<= 1mS	SP420PV	3	G
STP1000YPVM +	1000	1200	20	40	<4.0	10	<= 1mS	SP670PV	3	G
STP1200YPVM*** +	1200	1440	20	40	<6.0	2	<= 1mS	SP745PV	3	G

* Ucpv: Maximum continuous operating DC voltage between L-G and L-L

**Short Circuit Current Rating values based upon SPD type 2 testing

+ Approved to IEC 61643-1

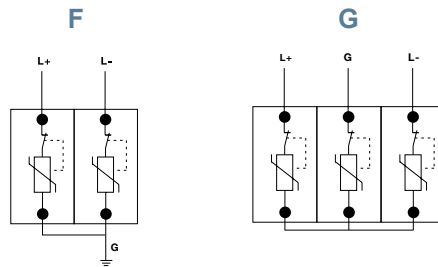

Surge-Trap[®] Modular SPDs

DIN-RAIL STYLE SPD

Surge-Trap Modular Surge Protective Device (SPD) is a no-fuse, fail-safe surge suppressor featuring Mersen's patented TPMOV[®] technology inside. The modular SPD is UL 1449 3rd Edition approved. It is DIN-rail mountable featuring a fail-safe self-protected design, visual indicator and a small footprint. A remote indicator option provides status to critical control circuitry. The Surge-Trap Modular SPD has a high short circuit rating and a thermally protected MOV, which eliminates the need for additional overcurrent protection devices.



Dimensions

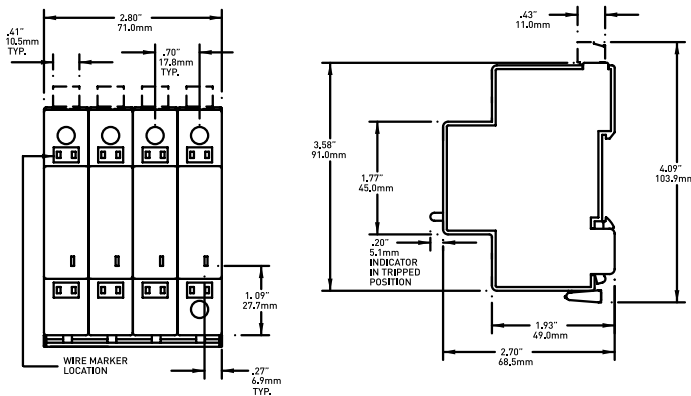

Poles	in	mm
1 Pole	0.70	17.8
2 Pole	1.39	35.5
3 Pole	2.10	53.3
4 Pole	2.80	71.0

** Wire Size: 6-14 AWG
** Torque: 15 lbs-in
** Use 35mm DIN-rail

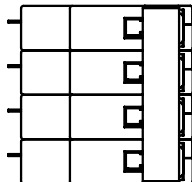

Features/Benefits

- Easy installation or retrofit
- DIN-rail mountable
- Fail-safe, self-protected design
- Remote indicator (optional)
- Visual indicator
- IP20 finger-safe design
- Small footprint
- No additional overcurrent protection devices required

Applications

- AC/DC distribution
- Power supplies
- Industrial automation
- Telecommunications
- Motor controls and starter systems
- Programmable logic controller (PLC) applications
- Power transfer equipment
- HVAC applications
- AC drives
- UPS systems
- Security systems
- IT/Data centers
- Medical equipment

Ratings

- Volts**
- 120V to 600V AC
- SCCR**
- 200kA
- Operating & storage temp**
- -25°C to +60°C
- Wiring range:**
- #6 to #14AWG
- Nominal discharge current**
- 20kA

Approvals

- UL 1449 3rd Edition Approved, File E210793
- Type 4 UL Recognized Component
- RoHS Compliant
- ANSI/IEEE C62.41
- CE



Surge-Trap[®] Modular SPDs

DIN-RAIL STYLE SPD



Product Type	Voltage	System Type	Mode	Auxiliary Microswitch
ST	480	3PY	G	M
ST- Modular	120 120/208 120/240 240 277 347 480 240/480 277/480 347/600	1P - Single Phase SP - Split Phase 3PD - 3 Phase Delta 3PY - 3 Phase Wye	Blank - Includes N-G Mode G - Does Not Provide N-G Mode	Blank - No Microswitch M - Microswitch Included

Catalog Numbers

Catalog No.	Nominal Voltage (VAC)	MCOV L-G	No. of Poles	System Type	Nominal Discharge Current ** (In, kA)	Max. Discharge Current (Imax, 8/20μs, kA)	SCCR (kA)	Freq (Hz)	Voltage Protection Rating (VPR)				No. of Wires	Circuit Connection Wiring Diagrams
									L-N	L-G	N-G	L-L		
ST1201PG(M)	120	180	1	1P	20	50	200	50/60	500	-	-	-	2	A
ST2301PG(M)	240	270	1	1P	20	50	200	50/60	800	-	-	-	2	A
ST2771PG(M)	277	320	1	1P	20	50	200	50/60	900	-	-	-	2	A
ST2083PY(M)	120/208	360	4	3PY	20	50	200	50/60	500	900	500	900	5	D
ST2083PYG(M)	120/208	180	3	3PY	20	50	200	50/60	500	-	-	900	4	C
ST240SPG(M)	120/240	180	2	SP	20	50	200	50/60	500	-	-	900	3	B
ST480SPG(M)	240/480	270	2	SP	20	50	200	50/60	800	-	-	1500	3	B
ST2403PDG(M)	240D	270	3	3PD	20	50	200	50/60	-	800	-	1500	4	C
ST4803PY(M)	277/480	500	4	3PY	20	50	200	50/60	1000	1500	500	1800	5	D
ST4803PYG(M)	277/480	320	3	3PY	20	50	200	50/60	900	-	-	1800	4	C
ST4803PDG(M)	480D	550	3	3D	20	50	200	50/60	-	1500	-	3000	4	C
ST6003PY(M)	347/600	690	4	3PY	20	50	200	50/60	1500	2500	800	2500	5	D
ST6003PYG(M)	347/600	420	3	3PY	20	50	200	50/60	1200	-	-	2000	4	C

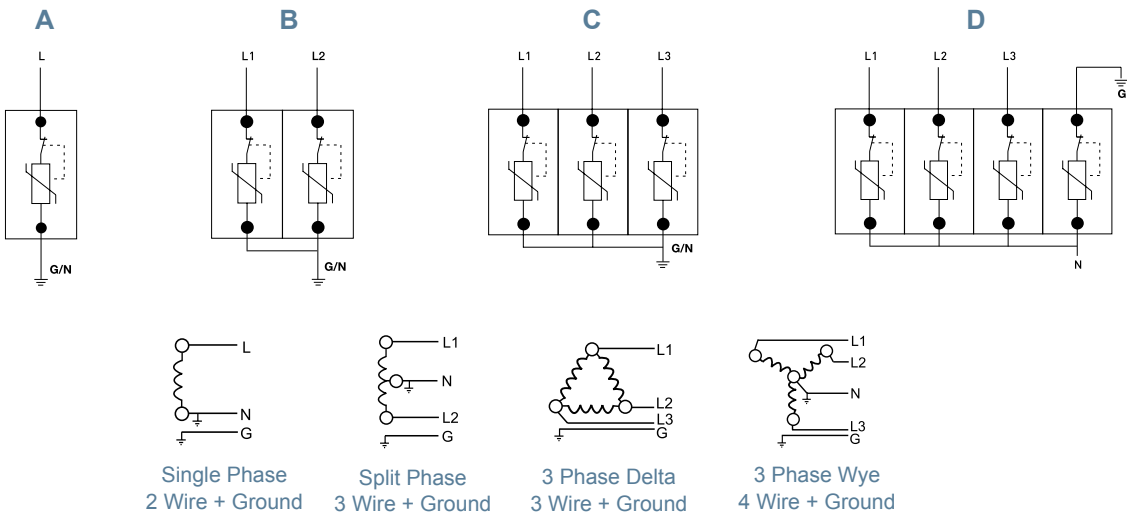

Surge-Trap[®] Type 1 SPDs

OUTDOOR AND INDOOR APPLICATIONS

Specifically designed to meet UL1449 standards, the Surge-Trap Type 1 SPD for indoor and outdoor applications features Mersen's industry leading patented TPMOV[®] technology. Offering an economical replacement for the former secondary surge arrestors, the Surge-Trap Type 1 is a no-fuse surge suppressor solution that does not require additional overcurrent protection. Offering an innovative design and superior protection in a small footprint, the Surge-Trap Type 1 can be installed either upstream or downstream of the main disconnect.



Dimensions: STT2

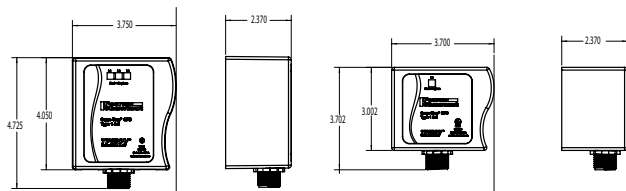

Dimensions: STT4X

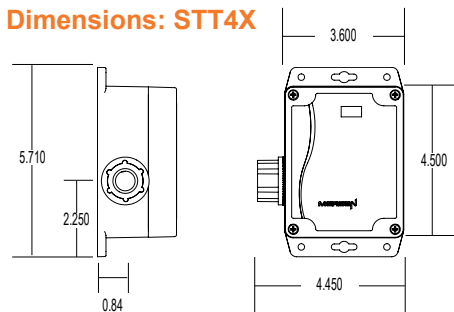

Approvals

- UL 1449 3rd Edition Approved, File E210793
- UL 96A Lightning Protection Master Label compliant (for 20kA, I_n —most models)
- Type 1 Listed for United States
- Type 2 Listed for Canada
- RoHS Compliant
- ANSI/IEEE C62.41
- CE

Applications

- AC/DC distribution
- Power supplies
- Industrial
- Commercial
- Telecommunications
- Residential
- IT/Data centers

Ratings

- Surge**
- 50kA per phase
- Volts**
- 120V to 600V AC
- SCCR**
- 200kA
- Operating & storage temp**
- -25°C to +60°C

Wiring size

- 16" #12 AWG integral leads

Enclosure

- STT2: NEMA 2
- STT4X: NEMA 4X



Surge-Trap[®] Type 1 SPDs

Outdoor and Indoor Applications



Catalog Numbers

Catalog No.	Catalog No. NEMA 4X Enclosure	Nominal Voltage (VAC)	System Type	Freq (Hz)	MCOV (L-N)	Nominal Discharge Current (n, kA)	Voltage Protection Rating (VPR)				Circuit Connection Wiring Diagrams
							L-N	L-G	N-G	L-L	
STT21201PG	STT4X1201PG	120	1	50/60	180	20	700	1200	600	-	A
STT2240SPG	STT4X240SPG	120/240	1S	50/60	180	20	700	-	-	1200	B
STT22401PG	STT4X2401PG	240	1	50/60	270	20	1000	1500	700	-	A
STT22083PYG	STT4X2083PYG	120/208	3Y	50/60	180	20	700	-	-	1200	D
STT24803PYG	STT4X4803PYG	277/480	3Y	50/60	320	10	1200	-	-	2000	D
STT26003PYG	STT4X6003PYG	347/600	3Y	50/60	420	10	1500	-	-	2500	D
STT22403PDG	STT4X2403PDG	240	3D	50/60	270 (L-G)	20	-	1000	-	1800	C
STT24803PDG	STT4X4803PDG	480	3D	50/60	550 (L-G)	10	-	1800	-	3000	C

Wiring Diagrams: STT2 and STT4X Single/Split Phase

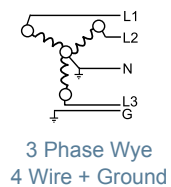
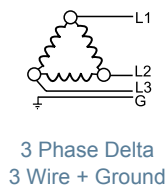
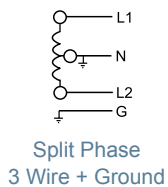
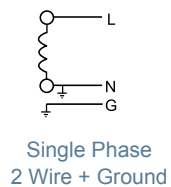
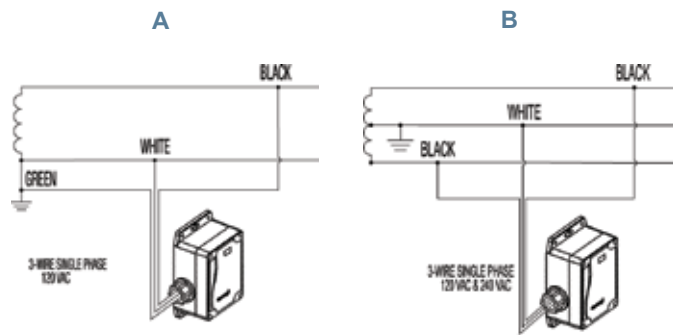

Three Phase Delta & Wye: STT2 and STT4X Three Phase Delta & Wye

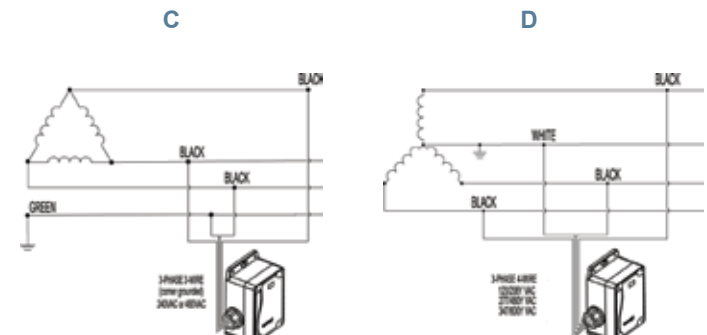

Installation Diagram STT2

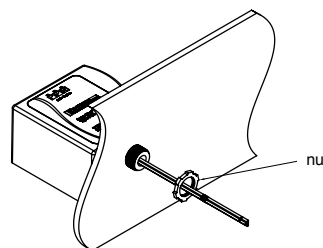

STT4X

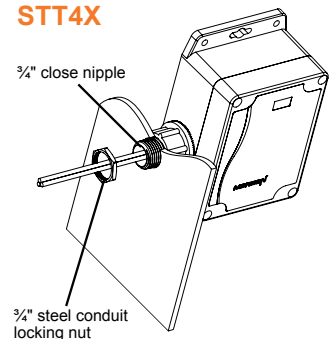

Surge-Trap[®] Type 1 SPDs

ENCLOSED OUTDOOR & INDOOR APPLICATIONS

The Surge-Trap X Series SPD's is Mersen's newest line of UL 1449 3rd edition approved surge protection devices (SPDs). Providing surge protection options for all locations in the smallest footprints available, the Surge-Trap X Series SPD's all meet requirements for UL 1449 3rd edition and feature Mersen's industry leading patented TPMOV[®] technology. A true "no-fuse" surge design, they do not require additional fuse components or overcurrent protection.



Features/Highlights

- UL 1449 3rd Edition Listed, Type 1 SPD
- Can be installed line-side or load-side of main disconnect
- 20kA Nominal discharge current
- 200kA SCCR (most models)
- UL 96A Lightning Protection Master Label compliant (20kA, I_n)
- TPMOV technology MOVs
- Pre-wired with 3' (1m) of #10 AWG conductor
- Standard NEMA 4X polycarbonate enclosure
- Tri-mount installation kit Included (pipe nipple, bracket, DIN-rail)
- 2-year warranty (XR), 10-year warranty (XP, XT)

Simple Installation

The Surge-Trap Type 1 X-Series SPDs have a NEMA 4X enclosure and can be installed line-side or load-side of the main disconnect. They have a 20kA nominal discharge current and 200kA SCCR rating (most models) and are suited for system voltages from 120V to 600V.

Green=Go Visual Diagnostic Monitoring

- Green LED = A-OK, Out = replace
- Visible from multiple sides & angles for better viewing
- Every MOV is monitored as opposed to 'power is present'

Approvals

- UL 1449 3rd Edition File VZCA.E210793
- CE
- ANSI/IEEE C62.41
- Burn-In tested prior to shipment
- UL 96A lightning protection master label

Mounting

- STD 3/4" -14 nipple
- DIN-rail mount
- Bracket mount (flat surface)

Applications

- AC/DC distribution
- Power supplies
- Drive Protection
- Fire Alarms
- Control Panels
- Telecommunications
- Residential
- IT/Data centers

Ratings

Surge

- 50kA per phase

Volts

- 120V to 600V AC

SCCR

- 200kA (most models)

Nominal discharge current

- 20kA rating
8x20µs pulse

Operating & storage temp

- -25°C to +60°C

Enclosure

- NEMA 4X



Surge-Trap[®] Type 1 SPDs

ENCLOSED OUTDOOR & INDOOR APPLICATIONS

The **Surge-Trap XR** Series is ideal for the replacement of obsolete surge arrestors. With a small, compact design and line or load installation flexibility, the XR series is the perfect fit from service entrance all the way down to a specific control panel.



Dimensions & Weight

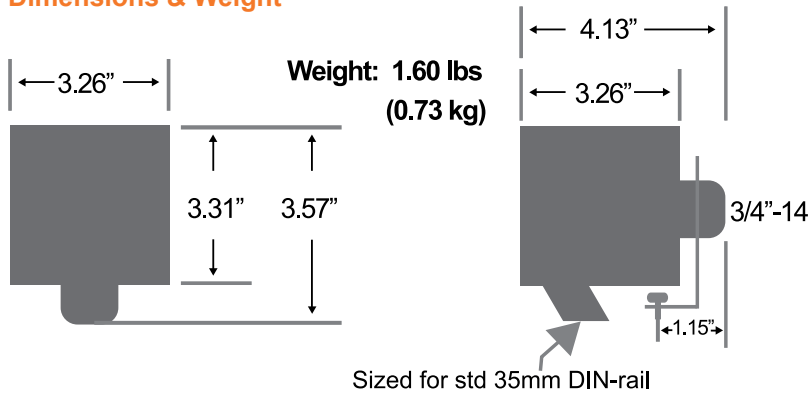

The **Surge-Trap XP** Series provides surge protection for larger distribution panels and branch panels. With a compact design and line or load installation flexibility, the XP series is prepared for mount from the service entrance all the way down to an important machine specific control panel.



Dimensions & Weight

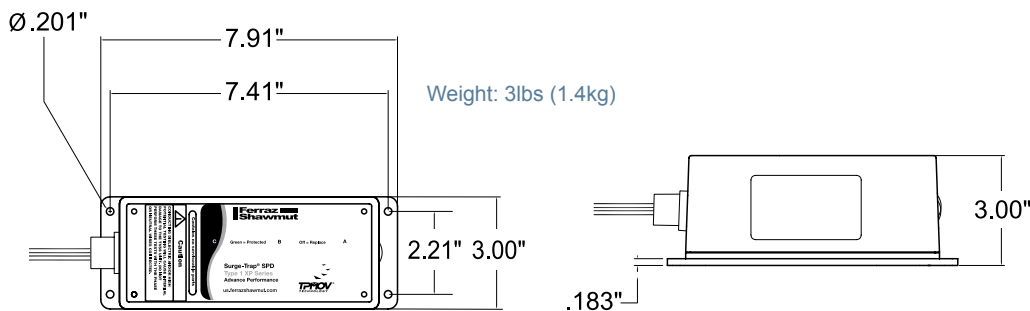

Surge-Trap[®] Type 1 SPDs

ENCLOSED OUTDOOR & INDOOR APPLICATIONS

The **Surge-Trap XT Series** offers the most advanced technology of the X Series product line utilizing TPMOV[®] technology. Designed to fit and protect the service entrance, the XT Series also features line or load side installation.



Dimensions & Weight

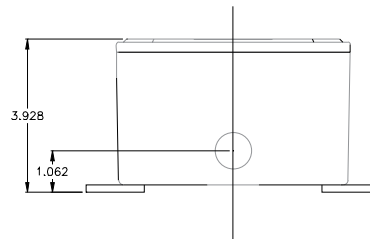
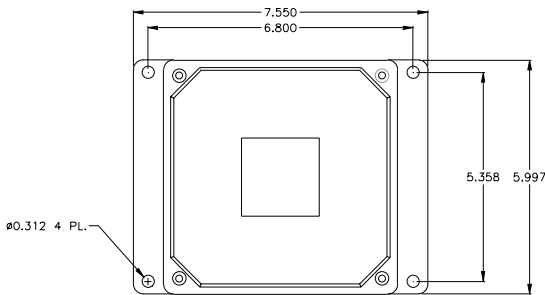

Weight: 5lbs (2.3kg)

Wiring Diagrams — XR, XP & XT

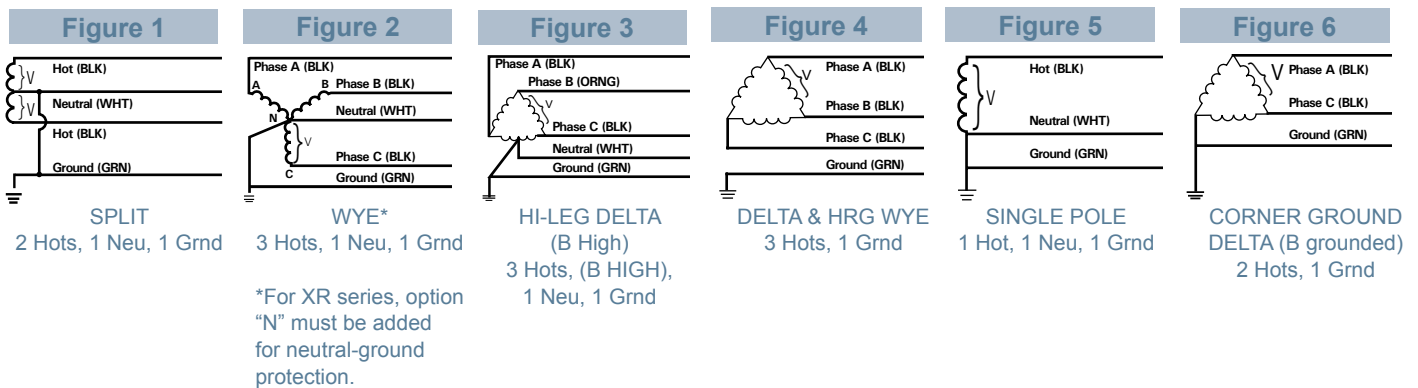

Surge-Trap® Type 1 SPDs

ENCLOSED OUTDOOR & INDOOR APPLICATIONS



Catalog Numbers - Ordering System

STXR Series	System Voltage	System Config	Surge Rating	Options
STXR	120V	1P = One Pole, Single Phase	50	Blank
	127V	2P = Two Pole, Split Phase		N = Neutral to Ground Protection on 50kA units
	220V	3Y = Three Pole Wye		D = Dry Contacts and Audible Alarm
	240V	3D = Three Pole Delta		F = Neutral and Ground modes reversed
	277V	3H = Three Pole Hi-Leg		P = LED and / or Diagnostics
	347V			R = Removes all Diagnostics
	480V			M = Provides TPMOV microswiches for use
	600V		8 = Replace 10AWG with 8AWG leads	
Example STXR480V3D50D				
STXR	480V	3D	50	D

* Please call factory for specific product performance data.

Catalog No.	System Voltage & Config.	UL 1449 3 rd Edition (Sept 2009) Voltage Protection Rating VPR 3000A				In	SCCR	MCOV
		L-N	L-L	N-G*	L-G*			
STXR120V1P50	120V	600		600*	1000*	20kA	200kA	150
STXR120V2P50	120V/240V	600	1000	600*	1000*	20kA	200kA	150
STXR120V3Y50	208Y/120V	600	1000	600*	1000*	20kA	200kA	150
STXR127V1P50	127V	700		600*	1200*	20kA	100kA	180
STXR127V2P50	127/254V	700	1200	600*	1200*	20kA	100kA	180
STXR127V3Y50	220Y/127V	700	1200	600*	1200*	20kA	100kA	180
STXR220V1P50	220V-1 pole	1200		1000*	1800*	20kA	200kA	320
STXR220V3Y50	380Y/220V	1200	2000	1000*	1800*	20kA	200kA	320
STXR240V3H50	120/240V - Hi-Leg Delta	600/1200	1000/1500	600	1000/1500	20kA	200kA	150/320
STXR240V1P50	240V-1 pole	1200		1000	1800	20kA	200kA	320
STXR240V3D50	240V Delta -		1500		1200	20kA	200kA	321
STXR277V1P50	277V	1200		1000*	1800*	20kA	200kA	320
STXR277V2P50	240/480V	1200	2000	1000*	1800*	20kA	200kA	320
STXR277V3Y50	480Y/277V	1200	2000	1000*	1800*	20kA	200kA	320
STXR347V3Y50	600Y/347Y	1500	2500	1200*	2500*	20kA	200kA	420
STXR480V1P50	480V-1 pole	1800				10kA	200kA	550
STXR480V3D50	480V Delta - 3 Pole		3000		1800	10kA	200kA	550
STXR480V3H50	240/480V -Hi-Leg Delta	1200/1800	2500			10kA	200kA	320/550
STXR600V3D50	600V Delta - 3 Pole		2500		2500	20kA	200kA	690

Surge-Trap® Type 1 SPDs

ENCLOSED OUTDOOR & INDOOR APPLICATIONS



Catalog Numbers - Ordering System

STXP	System Voltage	S	Surge Rating	Enclosure	Options			
STXP	Common System Configurations				Blank			
	01 = 240/120V Split Phase - 1Φ 3W+Grnd (Fig 1)	S	100	4X	A = Audible Alarms & Dry Contacts			
	02 = 208Y/120V Wye - 3Φ 4W+Grnd (Fig 2)				E = Remote Indicator (on 6ft cable)			
	03 = 240/120V High Leg Delta (B High) (Fig 3)				L = Deletes L-N protection			
	04 = 480Y/277V Wye - 3Φ 4W+Grnd (Fig 2)				G = Deletes L-G protection			
	05 = 480V Delta - 3Φ 3W+Grnd (Fig 4) & HRG Wye				N = Deletes N-G protection			
	08 = 600Y/347V Wye -3Φ 4W+Grnd (Fig 2)				R = Alternate lead length			
	Other System Configurations Available							
	06 = 240V Delta - 3Φ 3W+Grnd (Fig 4)							
	07 = 380Y/220V Wye - 3Φ 4W+Grnd (Fig 2)							
	09 = 600V Delta - 3Φ 3W+Grnd (Fig 4) & HRG Wye							
	11 = 120V Single Phase (Fig 5)							
	12 = 240V Single Phase (Fig 5) - Not split phase							
	13 = 127V Single Phase (Fig 5)							
	14 = 300V Single Phase (Fig 5)							
	15 = 254/127V Split Phase - 1Φ 3W+Grnd (Fig 1)							
	16 = 277V Single Phase (Fig 5)							
	17 = 480V Single Phase (1 Hot, 1 Neu, 1 Grnd) (Fig 5)							
	18 = 480/277 2-Pole, (480/240V Split Phase) (Fig 1)							
	21 = 220Y/127V Wye - 3Φ 4W Grnd (Fig 2)							
	41 = 520Y/300V Wye- 3Φ 4W+Grnd (Fig 2)							
	42 = 415Y/240V Wye-3Φ 4W+Grnd (Fig 2)							
	43 = 400Y/230V Wye - 3Φ 4W+Grnd (Fig 2)							
	44 = 440Y/250V Wye - 3Φ 4W+Grnd (Fig 2)							
51 = 480V B Corner Grnd Delta, 3Φ 3W+Grnd (Fig 6)								
61 = 240V B Corner Grnd Delta, 3Φ 3W+Grnd (Fig 6)								
91 = 600V B Corner Grnd Delta, 3Φ 3W+Grnd (Fig 6)								
Example STXP05S1004XE								
STXP	05	S	100	4X	E			

Performance Data

Common North American Systems		UL 1449 3 rd Edition (Sept 2009) Test Data								
		Voltage Protection Ratings (VPR - 3kA)							SCCR	MCOV
		L-N	L-G	N-G	L-L	Type	In			
01 =	240/120V Split Phase	600	700	500	1000	Type 1	20kA	100kA	150	
02 =	208Y/120V 3Ø Wye	600	700	500	1000	Type 1	20kA	200kA	150	
03 =	240Y/120V B High Leg Delta	600/1200	700/1200	500	1000	Type 1	20kA	200kA	150 / 320	
04 =	480Y/277V 3Ø Wye	1200	1200	1000	1800	Type 1	20kA	200kA	320	
05 =	480V 3Ø Delta	-	1800	-	1800	Type 1	10kA	200kA	552	
08 =	600Y/347V 3Ø Wye	1500	1500	1500	2500	Type 1	10kA	200kA	420	

Surge-Trap® Type 1 SPDs

ENCLOSED OUTDOOR & INDOOR APPLICATIONS



Catalog Numbers - Ordering System

STXT	System Voltage	S	Surge Rating	Enclosure	Options				
STXT	Common System Configurations	S	100 200 200 200 200 200	4X	Blank				
	01 = 240/120V Split Phase - 1Φ 3W+Grnd (Fig 1)				A = Audible Alarms & Dry Contacts				
	02 = 208Y/120V Wye - 3Φ 4W+Grnd (Fig 2)				E = Remote Indicator (6ft cable)				
	03 = 240/120V High Leg Delta (B High) (Fig 3)				L = Deletes L-N protection				
	04 = 480Y/277V Wye - 3Φ 4W+Grnd (Fig 2)				G = Deletes L-G protection				
	05 = 480V Delta - 3Φ 3W+Grnd (Fig 4) & HRG Wye				N = Deletes N-G protection				
	08 = 600Y/347V Wye -3Φ 4W+Grnd (Fig 2)				R = Alternate lead length				
	Other System Configurations Available								
	06 = 240V Delta - 3Φ 3W+Grnd (Fig 4)								
	07 = 380Y/220V Wye - 3Φ 4W+Grnd (Fig 2)								
	09 = 600V Delta - 3Φ 3W+Grnd (Fig 4) & HRG Wye								
	11 = 120V Single Phase (Fig 5)								
	12 = 240V Single Phase (Fig 5) - Not split phase								
	13 = 127V Single Phase (Fig 5)								
	14 = 300V Single Phase (Fig 5)								
	15 = 254/127V Split Phase - 1Φ 3W+Grnd (Fig 1)								
	16 = 277V Single Phase (Fig 5)								
	17 = 480V Single Phase (1 Hot, 1 Neu, 1 Grnd) (Fig 5)								
	18 = 480/277 2-Pole, (480/240V Split Phase) (Fig 1)								
	21 = 220Y/127V Wye - 3Φ 4W Grnd (Fig 2)								
	41 = 520Y/300V Wye- 3Φ 4W+Grnd (Fig 2)								
	42 = 415Y/240V Wye-3Φ 4W+Grnd (Fig 2)								
	43 = 400Y/230V Wye - 3Φ 4W+Grnd (Fig 2)								
	44 = 440Y/250V Wye - 3Φ 4W+Grnd (Fig 2)								
	51 = 480V B Corner Grnd Delta, 3Φ 3W+Grnd (Fig 6)								
	61 = 240V B Corner Grnd Delta, 3Φ 3W+Grnd (Fig 6)								
	91 = 600V B Corner Grnd Delta, 3Φ 3W+Grnd (Fig 6)								
	Example				STXT04S2004XA				
	STXT				04	S	200	4X	A

Performance Data

Common North American Systems			UL 1449 3 rd Edition (Sept 2009) Test Data							
			Voltage Protection Ratings (VPR - 3kA)							
			L-N	L-G	N-G	L-L	Type	In	SCCR	MCOV
01	=	240/120V Split Phase	700	700	600	1000	Type 1	20kA	100kA	150
02	=	208Y/120V 3Ø Wye	700	700	600	1000	Type 1	20kA	200kA	150
03	=	240Y/120V B High Leg Delta	700/1200	700/1200	600	1000/2000	Type 1	20kA	200kA	150 / 320
04	=	480Y/277V 3Ø Wye	1200	1200	1200	2000	Type 1	20kA	200kA	320
05	=	480V 3Ø Delta	-	1800	-	2000	Type 1	10kA	200kA	550
08	=	600Y/347V 3Ø Wye	1500	1500	1500	2500	Type 1	10kA	200kA	420

Important Changes to UL 1449 3rd Edition



Since 1985, Underwriters Laboratory (UL) 1449 standard has been providing safety guidelines for Surge Suppression. Originally titled “The Standard for Safety for Transient Voltage Surge Suppressor,” this standard was initially created to provide structure to a rapidly developing and growing industry and was largely based on waveforms and testing methods from IEEE C62.41. Over time, new developments and enhanced technology has driven the need for more rigorous standards. As a result of these advances, UL responded on September 29, 2009 by making significant revisions to standard 1449 updating it to the 3rd edition.

New, More Rigorous Test Requirements in UL 1449 3rd Edition

Previously, UL 1449 2nd edition referred to the clamp voltage test as the suppressed voltage rating (SVR) which consisted of a 500A, 6000V surge. Updated in UL 1449 3rd edition, the clamp voltage test is referred to as the voltage protection rating (VPR) and consists of a 3,000A, 6000V surge – **more than 6 times more surge current required than that of the previous 2nd edition**. This means the VPR for an SPD will be higher than the SVR of an identical SPD. Higher current levels equal higher clamp voltages.

The change from SVR to VPR is the single most important change in the UL 1449 3rd edition relating to specifiers. The SVR listed in current specifications will be obsolete since comparing a VPR rating to a SVR rating would provide no information of value. **To be sure than there is an accurate performance comparison, the VPR of one device must be compared with the VPR of another device.**

Also new to UL 1449 3rd edition standard is the nominal discharge current test (I_n). This new test requirement originates from the International Electrical Code (IEC) surge testing criteria, mandating that a SPD must remain functional after being subjected to 15 repetitive impulses of a specific value. During the I_n test, every mode of protection is tested, including any required overcurrent protection. The I_n values which a device must be tested at are as follows:

Type 1 device : 10kA or 20kA

Type 2 device: 3kA, 5kA, 10kA, or 20kA

Important to note is that the manufacturer has the ability to chose which I_n value the device is tested at, which means that SPD products need to be investigated in detail to understand the published ratings. In the event a device can not pass at any given value, it is permitted by UL that the SPD manufacturer can re-test at a lower level until a stable value is obtained to pass the test.

What do the changes to UL 1449 mean to you?

Since the effective date of September 29, 2009 all SPD products which do not meet UL 1449 3rd edition are to be considered obsolete. However, there are many SPDs on the market that no longer meet the standard but are still offered for sale. The simplest way to know if a SPD product is in compliance is to look for a UL holographic label on the device. If it has a UL “SPD” holographic label, it is in compliance and if it does not have one, it does not meet the new UL 1449 3rd edition standard.



The picture to the left is of a holographic label from an obsolete 2nd edition device. Please note the TVSS wording.



The picture to the left is of a holographic label from a UL 1449 3rd edition device. Please note the SPD wording, which is accepted in today’s industry.



Main production sites

Industrial or commercial branch

MERSEN
Expertise, our source of energy

A WORLD LEADER
 in safety & reliability
 for electrical power.

A GLOBAL PLAYER

Since its foundation in 1892, MERSEN has built an international reputation by creating subsidiaries on all continents. Today with industrial and commercial plants scattered in more than 30 countries, agencies

and representatives in more than 70 countries and 250 commercial contacts throughout the world, MERSEN offers its customers everywhere reliable, high technology products and services backed by its expert technicians.

Mersen U.S.A.
 374 Merrimac Street
 Newburyport, MA 01950
 U.S.A.
 T : 978 462 6662
 F : 978 462 0181

Mersen FRANCE
 15 Rue Jacques de Vaucanson
 F-69720 Saint Bonnet de Mure
 France
 T : +33 (0)4 72 22 66 11
 F : +33 (0)4 72 22 67 13

Mersen TORONTO
 88 Horner Avenue
 Toronto, Ontario
 Canada M8Z 5Y3
 T : 416 252 9371
 F : 416 252 6572

Mersen SHANGHAI
 No.55-A6. Shu Shan Road
 Songjiang 201611
 Shanghai
 Tel: +8621 67602388

ep-us.mersen.com